

## Flowrite™ 599 Series

### Two-Way Valves

### 1/2 to 2-inch Bronze Body

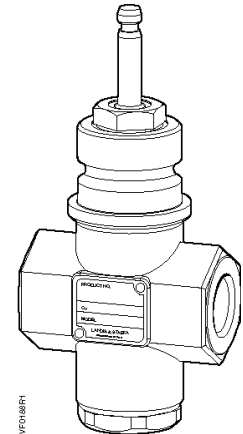

#### Description

The Flowrite 599 Series two-way valves are designed to work with either a pneumatic or electronic actuator with a 3/4-inch (20 mm) stroke. They are available in ANSI Class 250 for normally closed or normally open action.

#### Features

- Direct coupled universal bonnet
- Choice of two flow characteristics
- Choice of brass or stainless steel trim
- ANSI Leakage Class IV (0.01% of Cv)
- Cartridge type packing

#### Application

Flowrite valves are generally recommended for water, steam, and glycol solutions to 50%.

#### Product Numbers

See Tables 1 and 2.

#### Ordering a Valve Plus Actuator Assembly

To order a complete valve plus actuator assembly from the factory, combine the actuator prefix code with the suffix of the valve assembly product number. See *TB 249 Flowrite 599 Series Valve and Actuator Assembly Selection Technical Bulletin* (155-304P25) for selection procedure and ordering codes.

Valve assemblies can be ordered using the numbers in Tables 1 and 2.

<b>Specifications</b>	Line size	1/2 to 2 inches (15 to 50 mm)		
	Capacity	See Tables 3 through 6 and Figure 3		
	<b>Material</b>	Body style	Globe style control valve with four connection options See Tables 1 and 2	
		Seat style	Single seat, metal-to-metal	
		Action	Normally Closed (NC) Normally Open (NO)	
		Stem travel (stroke)	3/4-inch (20 mm)	
		Valve body rating	ANSI Class 250; see Table 7	
		Body	UNS CA 844 bronze	
		Body trim	See Tables 1 and 2	
		Stem	Stainless steel ASTM A582 Type 303	
		Packing		
		Normal duty packing	EPDM O-ring	
		Steam packing	Teflon <sup>®</sup> V-ring	
		<b>Operating</b>	Controlled medium	Saturated steam, water, glycol solutions to 50%
Medium temperature range				
Normal duty packing	20°F to 250°F (−7°C to 120°C)			
Steam packing	337°F (170°C) maximum			
Maximum inlet pressure				
Water	See Table 7			
Steam	100 psig (690 kPa)			
Maximum recommended differential pressure for modulating service				
	Brass trim		Stainless steel trim	
Liquid	25 psi (173 kPa)		50 psi (345 kPa)	
Steam	15 psi (103 kPa)		50 psi (345 kPa)	
Rangeability	>100:1			
Close-off pressures	See Tables 8 and 9 and Figure 4			
Close-off ratings	According to ANSI/FCI 70-2			
Leakage rate	Class IV (0.01% of Cv)			
Flow characteristics	See Tables 1 and 2			
Mounting location	NEMA 1 (interior only)			
<b>Miscellaneous</b>	Canadian Registration Numbers	0H7645.5 0C0838.9		
	Dimensions	See Tables 12 and 13 and Figure 6		
	Valve Weight	See Table 14		

**Accessories**

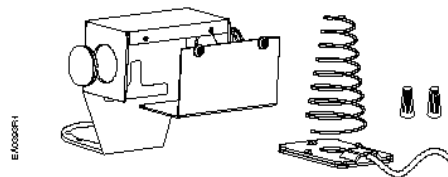
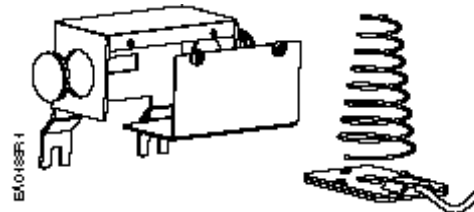

**Figure 1. Packing Heating Element For Use with SKD and SQX Actuators.**

**599-00417** Packing heating element.

The heater allows the stem to move freely in valves that control fluids at temperatures below 32°F (0°C). It reduces ice crystal formation on the stem, which can damage the packing.

Operating Voltage	24 Vac
Heating Output	20 W



**Figure 2. Packing Heating Element For Use with SKB/C and 8-inch Actuators.**

**599-00418:** Packing heating element.

The element allows the stem to move freely in valves that control fluids at temperatures below 32°F (0°C). It prevents ice crystal formation on the stem, which can damage the packing.

Operating Voltage	24 Vac
Heating Output	20 W

**Service Kits**

Valve packing kit	
Normal duty packing	599-03390
Steam packing	599-03391
Rebuild/repack kits	See Table 14
Sealing rings for union valves (package of 25)	
1/2-inch (15 mm)	599-03394
3/4-inch (20 mm)	599-03395
1 inch (25 mm)	599-03396
1-1/4 inch (32 mm)	599-03397
1-1/2 inch (40 mm)	599-03398
2 inch (50 mm)	599-03399
Union Tailpiece kit (one tailpiece, one union nut, one gasket.)	
1/2-inch (15 mm) male	599-09181
3/4-inch (20 mm) male	599-09182
1 inch (25 mm) male	599-09183
1-1/4 inch (32 mm) male	599-09184
1/2-inch (40 mm) female	599-09185
3/4-inch (20 mm) female	599-09186
1 inch (25 mm) female	599-09187
1-1/4 inch (32 mm) female	599-09188
1-1/2 inch (40 mm) female	599-09189
2 inch (50 mm) female	599-09190

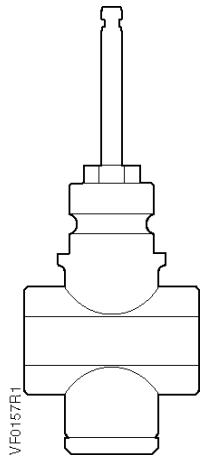

**Female NPT x Female NPT FxF**

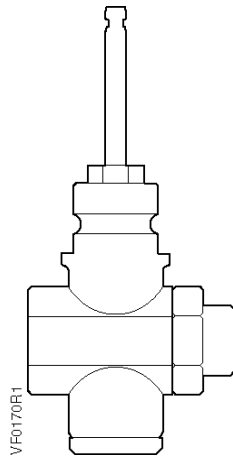

**Female NPT x Union Female FxUF**

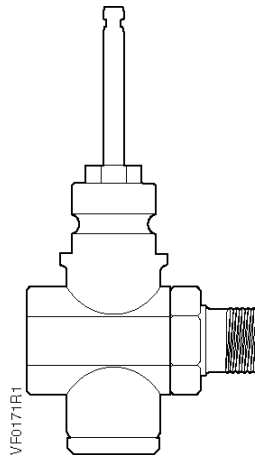

**Female NPT x Union Male FxUM**

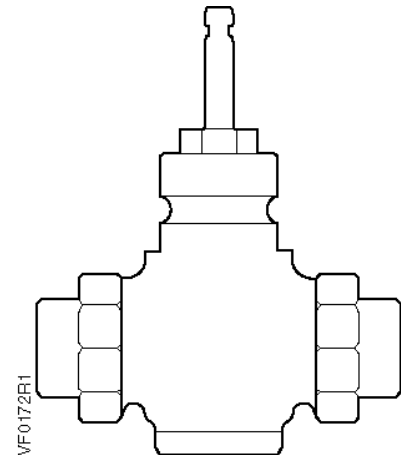

**Union Female x Union Female UFxUF**

**Table 1. Normally Closed Valves.**

Flow Rate		Nominal Line Size		Connection	Equal Percentage		Linear	
					Stl. Steel Trim	Brass Trim	Stainless Steel Trim	
Cv	(Kvs)	Inch	(mm)		Normal Duty Packing		Normal Duty Packing	Steam Packing
1	(0.85)	1/2	(15)	FxF	599-03126	599-03180	599-03018	599-03072
				FxUF	599-03135	599-03189	599-03027	599-03081
				FxUM	599-03261	599-03279	599-03225	599-03243
1.6	(1.37)	1/2	(15)	FxF	599-03127	599-03181	599-03019	599-03073
				FxUF	599-03136	599-03190	599-03028	599-03082
				FxUM	599-03262	599-03280	599-03226	599-03244
2.5	(2.15)	1/2	(15)	FxF	599-03128	599-03182	599-03020	599-03074
				FxUF	599-03137	599-03191	599-03029	599-03083
				FxUM	599-03263	599-03281	599-03227	599-03245
4	(3.44)	1/2	(15)	FxF	599-03129	599-03183	599-03021	599-03075
				FxUF	599-03138	599-03192	599-03030	599-03084
				FxUM	599-03264	599-03282	599-03228	599-03246
6.3	(5.43)	3/4	(20)	FxF	599-03130	599-03184	599-03022	599-03076
				FxUF	599-03139	599-03193	599-03031	599-03085
				FxUM	599-03265	599-03283	599-03229	599-03247
10	(8.6)	1	(25)	FxF	599-03131	599-03185	599-03023	599-03077
				FxUF	599-03140	599-03194	599-03032	599-03086
				FxUM	599-03266	599-03284	599-03230	599-03248
16	(13.8)	1-1/4	(32)	FxF	599-03132	599-03186	599-03024	599-03078
				UFxUF	599-03141	599-03195	599-03033	599-03087
25	(21.5)	1-1/2	(40)	FxF	599-03133	599-03187	599-03025	599-03079
				UFxUF	599-03142	599-03196	599-03034	599-03088
40	(34.4)	2	(50)	FxF	599-03134	599-03188	599-03026	599-03080
				UFxUF	599-03143	599-03197	599-03035	599-03089

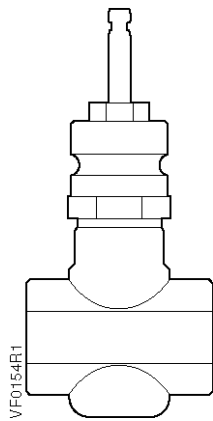

**Female NPT x Female NPT FxF**

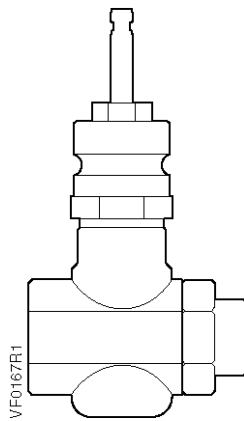

**Female NPT x Union Female FxUF**

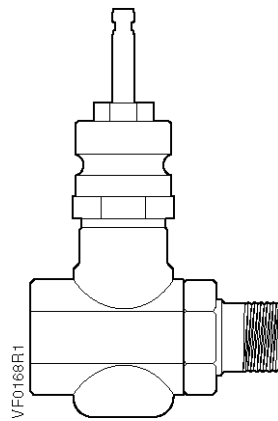

**Female NPT x Union Male FxUM**

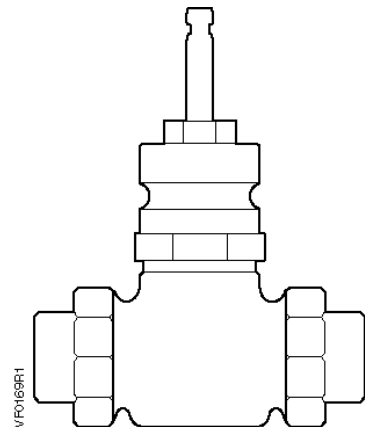

**Union Female x Union Female UFxUF**

**Table 2. Normally Open Valves.**

Flow Rate		Nominal Line Size		Connection	Equal Percentage		Linear	
					Stainless Steel Trim	Brass Trim	Stainless Steel Trim	
C <sub>v</sub>	(K <sub>vs</sub> )	inch	(mm)		Normal Duty Packing	Normal Duty Packing	Steam Packing	
1	(0.85)	1/2	(15)	FxF	599-03108	599-03162	599-03000	599-03054
				FxUF	599-03117	599-03171	599-03009	599-03063
				FxUM	599-03252	599-03270	599-03216	599-03234
1.6	(1.37)	1/2	(15)	FxF	599-03109	599-03163	599-03001	599-03055
				FxUF	599-03118	599-03172	599-03010	599-03064
				FxUM	599-03253	599-03271	599-03217	599-03235
2.5	(2.15)	1/2	(15)	FxF	599-03110	599-03164	599-03002	599-03056
				FxUF	599-03119	599-03173	599-03001	599-03065
				FxUM	599-03254	599-03272	599-03218	599-03236
4	(3.44)	1/2	(15)	FxF	599-03111	599-03165	599-03003	599-03057
				FxUF	599-03120	599-03174	599-03012	599-03066
				FxUM	599-03255	599-03273	599-03219	599-03237
6.3	(5.43)	3/4	(20)	FxF	599-03112	599-03166	599-03004	599-03058
				FxUF	599-03121	599-03175	599-03013	599-03067
				FxUM	599-03256	599-03274	599-03220	599-03238
10	(8.6)	1	(25)	FxF	599-03113	599-03167	599-03005	599-03059
				FxUF	599-03122	599-03176	599-03014	599-03068
				FxUM	599-03257	599-03275	599-03221	599-03239
16	(13.8)	1-1/4	(32)	FxF	599-03114	599-03168	599-03006	599-03060
				UFxUF	599-03123	599-03177	599-03015	599-03069
				FxUM	—	599-03276	—	—
25	(21.5)	1-1/2	(40)	FxF	599-03115	599-03169	599-03007	599-03061
				UFxUF	599-03124	599-03178	599-03016	599-03070
40	(34.4)	2	(50)	FxF	599-03116	599-03170	599-03008	599-03062
				UFxUF	599-03125	599-03179	599-03017	599-03071

**Table 3. Maximum Water Capacity - U.S. Gallons per Minute.**

Valve Size in inches	Pressure Differential - psi															
	Cv/1	2	3	4	5	6	8	10	15	20	25	30	40	50	60	75
1/2	1.0	1.4	1.7	2.0	2.2	2.5	2.8	3.2	3.9	4.5	5.0	5.5	6.3	7.1	7.8	8.7
	1.6	2.3	2.8	3.2	3.6	3.9	4.5	5.1	6.2	7.2	8.0	8.8	10.1	11.3	12.4	13.9
	2.5	3.5	4.3	5.0	5.6	6.1	7.1	7.9	9.7	11.2	12.5	13.7	15.8	17.7	19.4	22
	4	5.7	7	8.0	8.9	10	11.3	12.6	15.5	17.9	20.0	21.9	25	28	31	35
3/4	6	8.9	10.9	12.6	14.1	15.4	17.8	20	24	28	32	35	40	45	49	55
1	10	14.1	17.3	20	22	24	28	32	39	45	50	55	63	71	77	87
1-1/4	16	23	28	32	36	39	45	51	62	72	80	88	101	113	124	139
1-1/2	25	35	43	50	56	61	71	79	97	112	125	137	158	177	194	217
2	40	57	69	80	89	98	113	126	155	179	200	219	253	283	310	346

**Table 4. Maximum Water Capacity - Cubic Meters per Hour (m<sup>3</sup>/hr).**

Valve Size inches mm	Pressure Differential - kPa														
	1	10	20	30	40	50	60	80	Kvs/100	150	200	300	400	500	
15	0.09	0.3	0.4	0.5	0.5	0.6	0.7	0.8	0.9	1.0	1.2	1.5	1.7	1.9	
	0.14	0.4	0.6	0.8	0.9	1.0	1.1	1.2	1.4	1.7	1.9	2.4	2.7	3.1	
	0.2	0.7	1.0	1.2	1.4	1.5	1.7	1.9	2.2	2.6	3.0	3.7	4.3	4.8	
	0.3	1.1	1.5	1.9	2.2	2.4	2.7	3.1	3.4	4.2	4.9	6.0	6.9	7.7	
20	0.5	1.7	2.4	3.0	3.4	3.8	4.2	4.9	5.4	6.7	7.7	9.4	10.9	12.1	
25	0.9	2.7	3.8	4.7	5.4	6.1	6.7	7.7	8.6	10.5	12.2	14.9	17.2	19.2	
32	1.4	4.4	6.2	7.6	8.7	9.8	10.7	12.3	13.8	16.9	19.5	23.9	27.6	30.9	
40	2.2	6.8	9.6	11.8	13.6	15.2	16.7	19.2	22	26	30	37	43	48	
50	3.4	10.9	15.4	18.8	22	24	27	31	34	42	49	60	69	77	

**Table 5. Steam Capacity - Pounds per Hour.**

Line Size inches	Inlet Pressure - psig																								
	2			5			10			15			25			50			75			100			
	Pressure Differential - psi																								
	1	2	3	4	5	6	8	10	9	12	15	5	15	20	15	30	32.5	20	30	40	45	30	40	50	57.5
1/2	12.0	16.6	22	25	28	34	38	42	45	50	54	41	65	72	87	115	118	119	141	157	163	162	183	199	209
	19.1	27	35	40	44	54	61	67	72	80	86	65	104	116	139	183	188	109	225	251	261	260	292	318	334
	30	42	55	62	69	85	96	104	112	125	135	101	163	181	217	287	294	296	351	392	408	406	457	497	522
	48	67	88	100	110	136	153	167	179	200	216	162	261	289	348	459	471	474	562	627	653	650	731	796	835
3/4	75	105	138	157	174	213	241	263	282	316	341	255	411	455	548	722	742	747	886	988	1029	1023	1152	1253	1315
1	120	166	219	250	275	339	382	417	447	501	541	405	653	723	870	1147	1178	1186	1406	1568	1633	1624	1828	1989	2088
1-1/4	191	266	351	400	441	542	611	667	716	801	865	648	1044	1156	1392	1835	1884	1897	2249	2509	2612	2599	2925	3182	3340
1-1/2	299	416	549	625	689	847	955	1042	1118	1252	1351	1013	1632	1806	2175	2867	2944	2964	3515	3920	4081	4061	4570	4972	5219
2	478	666	878	1000	1102	1356	1529	1667	1789	2003	2162	1620	2611	2890	3480	4587	4710	4743	5624	6272	6530	6497	7311	7956	8350

**Table 6. Steam Capacity - Kilograms per Hour.**

Line Size mm	Inlet Pressure - kPa											
	100			150			200			500		
	Pressure Differential - kPa											
	10	20	50	15	30	75	20	40	100	50	100	250
15	6.04	8.54	13.50	9.07	12.8	20.2	12.11	17.13	27.08	30.3	42.9	67.8
	9.66	13.6	21.61	14.5	20.5	32.4	19.37	27.40	43.32	48.51	68.60	108.47
	15	21	34	23	32	51	30	43	68	76	107	169
	24	34	54	36	51	81	48	69	108	121	172	271
20	38	54	85	57	81	128	76	108	171	191	270	427
25	60	85	135	91	128	203	121	171	271	303	429	678
32	97	137	216	145	205	325	194	274	433	485	686	1085
40	151	214	338	227	321	507	303	428	677	758	1072	1695
50	242	342	540	363	513	812	484	685	1083	1213	1715	2712

**Table 7. Body Temperature-Pressure Rating.**

Valve Body	Temperature		Pressure
	°F	°C	psig (kPa)
Bronze	-20 to +150	(-30 to 66)	400 (2758)
	+200	(93)	385 (2655)
	+250	(121)	365 (2586)
	+300	(149)	335 (2300)
	+350	(177)	300 (2068)

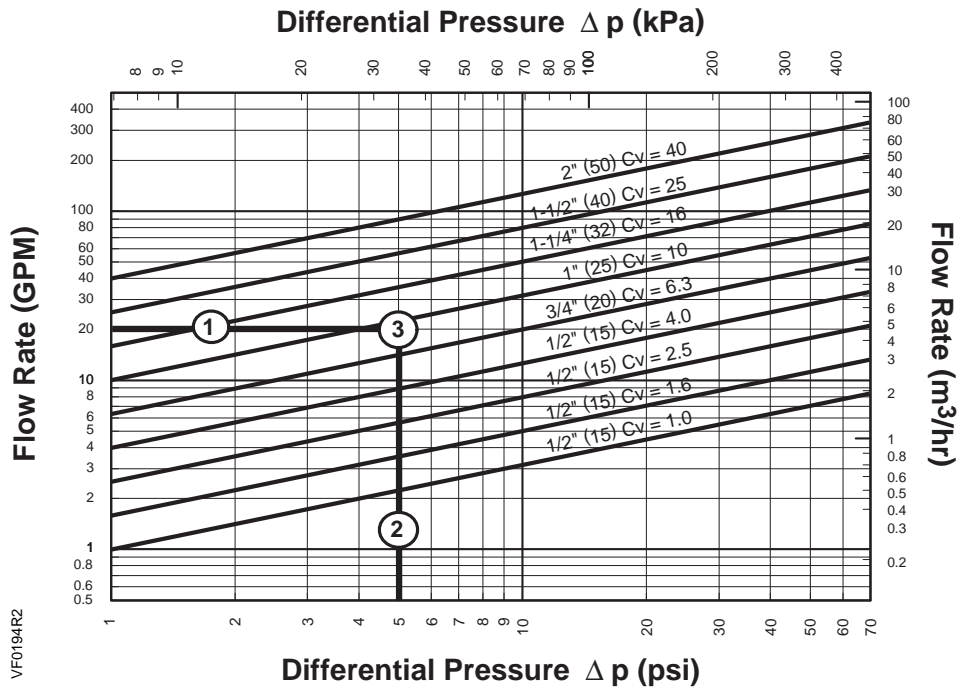

**Figure 3. Water Capacity Graph.**

**Selection Example**

Select a valve given:

1. Required flow = 20 gpm.
2. Desired pressure drop = 5 psi.
3. Select a 1-inch (25 mm) valve, Cv 10.



**Table 8. Maximum Available Close-off Pressures for Pneumatic Actuators, Action, Upper Port.**

NC (Upper port)	Valve Size Inch (mm)	10 to 15 psi (69 to 103 kPa) spring range		
		4-inch Actuator	8-inch Actuator	12-inch Actuator
		0 psi (0 kPa)	0 psi (0 kPa)	0 psi (0 kPa)
	1/2 (15)	236 (1627)	250 (1724)	—
	3/4 (20)	155 (1069)	250 (1724)	—
	1 (25)	91 (627)	250 (1724)	250 (1724)
	1-1/4 (32)	52 (359)	148 (1020)	250 (1724)
	1-1/2 (40)	32 (331)	92 (634)	250 (1724)
	2 (50)	20 (138)	55 (379)	185 (1275)

**Table 9. Maximum Available Close-off Pressures for Pneumatic Actuators, Action, Bottom Port.**

NO (Bottom Port)	Valve Size Inch (mm)	3 to 8 psi (21 to 55 kPa) spring range				
		4-inch Actuator	8-inch Actuator		12-inch Actuator	
		15 psi (103 kPa)	15 psi (103 kPa)	30 psi (207 kPa)	15 psi (103 kPa)	30 psi (207 kPa)
	1/2 (15)	142 (979)	250 (1724)	250 (1724)	—	—
	3/4 (20)	80 (552)	231 (1593)	250 (1724)	—	—
	1 (25)	52 (359)	150 (1034)	250 (1724)	250 (1724)	250 (1724)
	1-1/4 (32)	32 (221)	93 (641)	250 (1724)	250 (1724)	250 (1724)
	1-1/2 (40)	20 (138)	60 (414)	198 (1365)	205 (1413)	250 (1724)
	2 (50)	12 (83)	37 (255)	123 (848)	130 (896)	250 (1724)

**Table 10. Close-off Pressures for Electronic Actuators.**

Action	Valve Size Inches (mm)	SKB	SKD	SQX	EI/Mech Low Force	Rack & Pinion Valve
		psi (kPa)	psi (kPa)	psi (kPa)	psi (kPa)	psi (kPa)
NC	.50 (15)	250 (1724)	250 (1724)	250 (1724)	250 (1724)	250 (1724)
	.75 (20)	250 (1724)	250 (1724)	221 (1524)	238 (1640)	250 (1724)
	1.0 (25)	250 (1724)	203 (1400)	130 (896)	140 (965)	173 (1193)
	1.25 (32)	250 (1724)	117 (807)	75 (517)	81 (558)	100 (690)
	1.50 (40)	208 (1334)	73 (503)	46 (317)	50 (345)	61 (421)
	2.0 (50)	126 (869)	44 (303)	28 (193)	31 (214)	37 (255)
NO	.50 (15)	250 (1724)	250 (1724)	250 (1724)	250 (1724)	250 (1724)
	.75 (20)	250 (1724)	250 (1724)	173 (1193)	186 (1282)	231 (1593)
	1.0 (25)	250 (1724)	201 (1386)	112 (772)	121 (834)	149 (1028)
	1.25 (32)	250 (1724)	124 (855)	69 (476)	75 (517)	92 (634)
	1.50 (40)	250 (1724)	80 (552)	44 (303)	48 (331)	59 (407)
	2.0 (50)	201 (1386)	49 (338)	27 (186)	30 (207)	36 (248)

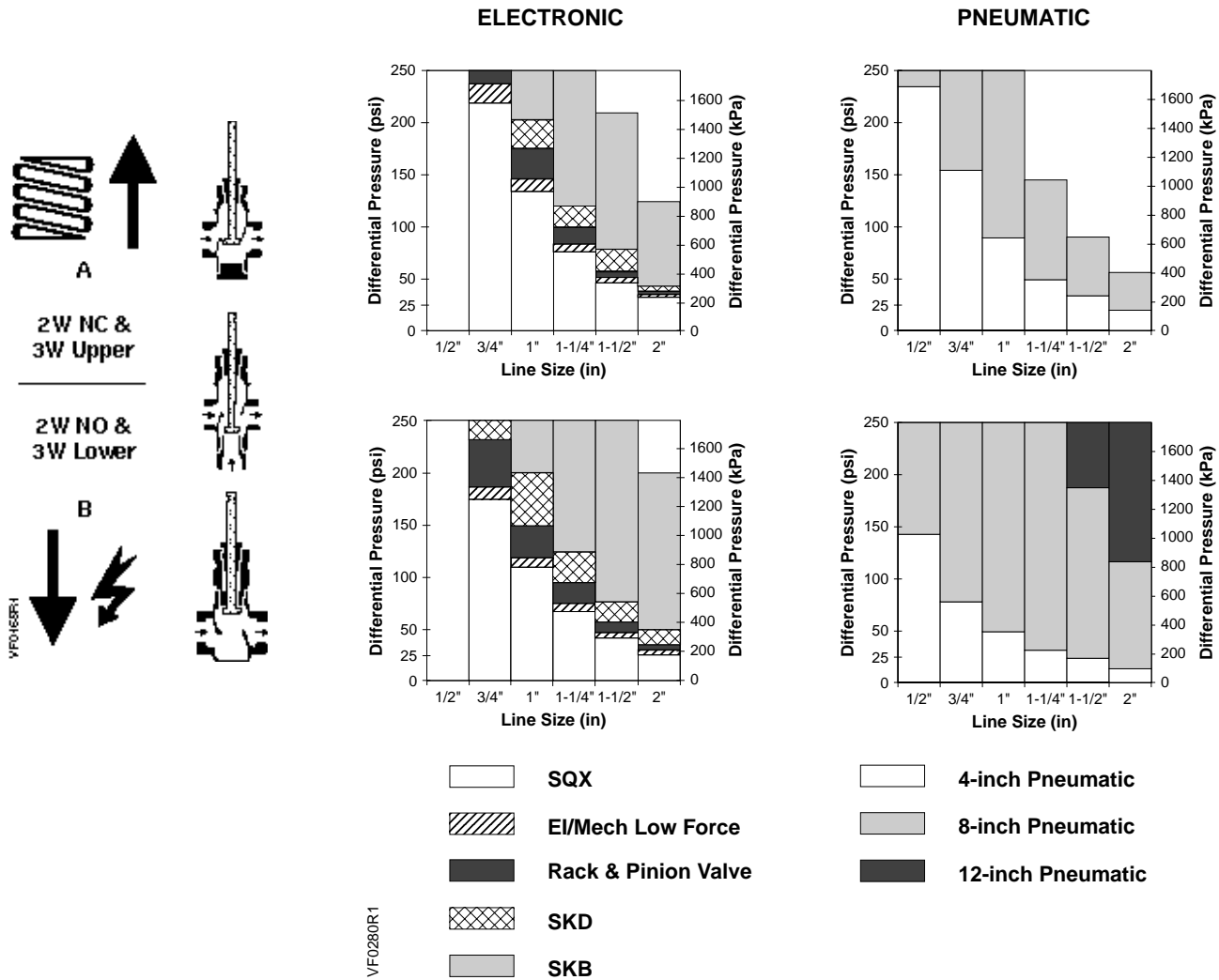

Figure 4. Close-off Pressures.

**Operation**

Figure 5 shows the normally open valve in the open or full flow position and the normally closed valve in the closed or zero flow position. The actuator spring provides the necessary force to hold the stem in the raised or normal position.

In the event of power failure, a spring return actuator returns the valve to its normal position. Non-spring return actuators will hold the last commanded position. See the *Technical Instructions* of the various actuators for additional information.

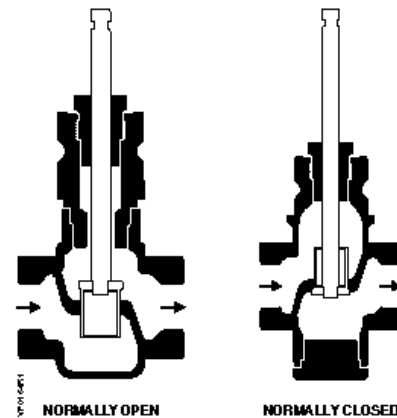

Figure 5.

---

## Sizing

The sizing of a valve is important for correct system operation. An undersized valve will not have sufficient capacity at maximum load. An oversized valve can initiate cycling and the seat and throttling plug can be damaged because of the restricted opening. Correct sizing of the control valve for *actual expected conditions* is considered essential for good control.

The following variables must be determined:

- The medium to be controlled, such as steam, water, etc.
- The maximum inlet temperature and pressure of the medium at the valve.
- The pressure differential that will exist across the valve under maximum load demand.
- The maximum capacity the valve must deliver.
- The maximum line pressure differential the valve actuator must close against.
- See the *Control Valve Selection and Sizing (AB-1) section of HVAC Systems/Controls Reference Data (125-1853)* for further recommendations.
- See Tables 3 through 6 for valve capacities.

---

## Mounting and Installation

- Install the valve so that the flow follows the direction of the arrow indicated on the valve body.
- For best performance, install the valve assembly with the actuator above the valve body. The valve and actuator can be installed in any position between vertical and horizontal. Siemens Building Technologies does not recommend installing the valve assembly so that the actuator is below horizontal or upside down.
- Allow sufficient space for servicing the valve and actuator. See Table 11 for valve body dimensions. See Figure 6 and Table 10 for dimensions of the service envelope recommended around the actuator.

**NOTE:** Instructions for field mounting an actuator, wiring diagrams, and start-up are covered in the Technical Instructions and Installation Instructions for each actuator.

---

## Dimensions

The letters in Figure 6 refer to actuator and service envelope dimensions in Table 11. See Table 12 for valve body dimensions.

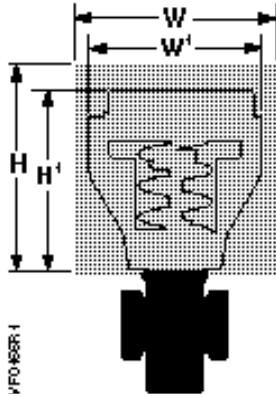
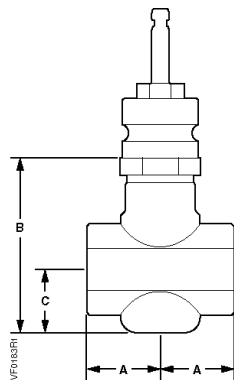

Figure 6. Dimensions.

**Table 11. Dimensions of the Actuator and Recommended Service Envelope.**  
 Dimensions in Inches (Millimeters).

Actuator	Actuator Prefix Code	Actual Height of Actuator H1	Service Height H	Actual Width or Diameter of Actuator W1	Service Width W
4-inch Pneumatic	268, 269 270	5-3/4 (146)	14 (350)	5-1/2 (137) diameter	18 (450)
8-inch Pneumatic	277, 278 283, 284	14-1/8 (359)	26 (660)	8-3/4 (222) diameter	21 (533)
12-inch Pneumatic	279, 285	17-7/8 (454)	30 (762)	15-1/8 (384) diameter	27 (686)
SKB	289, 291	14-3/4 (375)	22-3/4 (578)	14x9 (335 x228)	25 (635)
SKD	274, 275 276, 279	11-13/16 (300)	19-3/4 (500)	5 (127) Width 6-5/8 (169) Depth	14-1/2 (360)
SQX	271, 272 273	8-7/8 (226)	17 (430)	5-17/32 (140) Width 4-3/8 (111) Depth	13-1/2 (340)
EI/Mech with linkage	295, 296 297	11 (280)	22 (559)	5-3/4 (144) Width 8-7/8 (225) Depth	25-3/4 (654)
Rack and Pinion	298, 299	14-1/2 (368)	24 (622)	5 (127) width* 5-1/8 (131) depth	13-1/2 (334)

**Dimensions,  
 Continued**



**Female NPT by  
 Female NPT FxF**

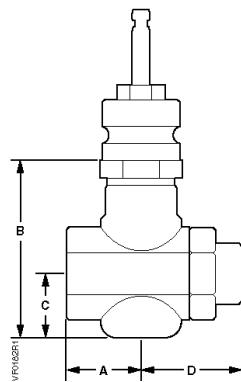

**Female NPT x Union Female  
 FxUF**

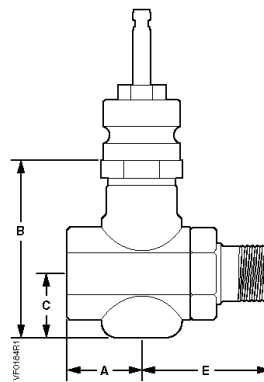

**Female NPT x Union  
 Male FxUM**

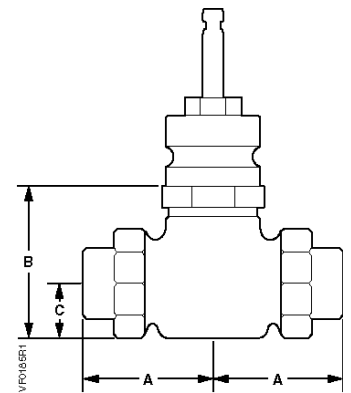

**Union Female x Union Female  
 UFxUF**

**Table 12. 2-Way Valve Dimensions in Inches (Millimeters).**

Valve Action	Valve Size	A		B	C	D FxUF	E FxUM
		FxF, FxUF, and FxUM	UFxUF				
Normally Closed	1/2 (15)	1-7/16 (36)	—	3-13/16 (97)	2-3/16 (55)	2-5/16 (59)	2-7/8 (73)
	3/4 (20)	1-11/16 (43)	—	3-13/16 (97)	2-3/16 (55)	2-5/8 (67)	3-3/16 (81)
	1 (25)	2 (50)	—	3-13/16 (97)	2-3/16 (55)	3 (76)	3-1/2 (89)
	1-1/4 (32)	2-1/2* (62)*	3-3/4 (95)	3-13/16 (97)	2-3/16 (55)	—	—
	1-1/2 (40)	2-9/16* (65)*	3-15/16 (99)	3-7/8 (99)	2-1/4 (58)	—	—
	2 (50)	3-1/8* (79)*	4-9/16 (115)	4-1/2 (114)	2-9/16 (65)	—	—
Normally Open	1/2 (15)	1-7/16 (36)	—	2-15/16 (74)	1-1/4 (31)	2-5/16 (59)	2-7/8 (73)
	3/4 (20)	1-11/16 (43)	—	3-15/16 (99)	1-7/16 (36)	2-5/8 (67)	3-3/16 (81)
	1 (25)	2 (50)	—	3-3/4 (96)	1-1/4 (32)	3 (76)	3-1/2 (89)
	1-1/4 (32)	2-1/2* (62)*	3-3/4 (95)	4-1/4** (108)**	2** (51)**	—	4-3/8 (111)
	1-1/2 (40)	2-9/16* (65)*	3-15/16 (99)	4-1/4** (108)**	2** (51)**	—	—
	2 (50)	3-1/8* (79)*	4-9/16 (115)	4-9/16** (116)**	2-1/4** (57)**	—	—

\* FxUF is not available as standard in 1-1/4, 1-1/2, and 2-inch valves.

FxUM is not available as standard in 1-1/2, and 2-inch-valves.

\*\* This dimension is determined by the union nut.

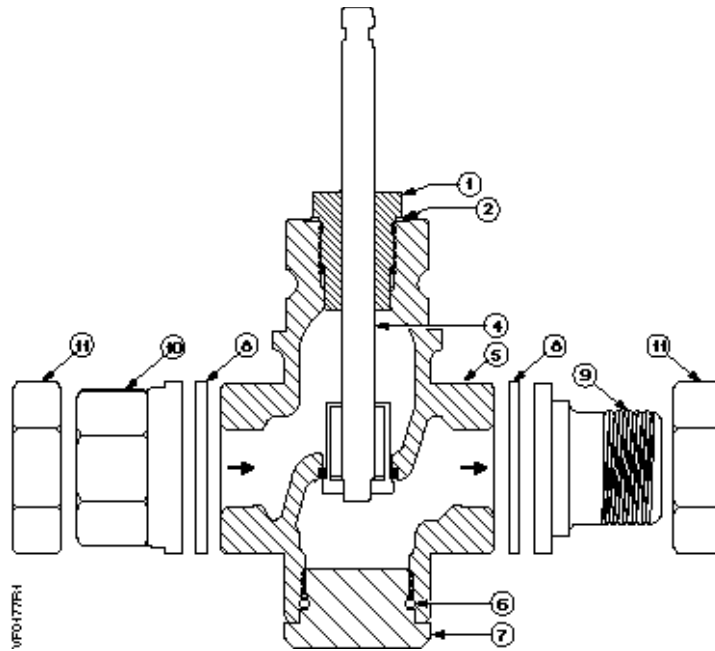

**Figure 7. Normally Closed**  
**1/2-inch to 2-inch (15 to 50 mm) Line Size Valve.**

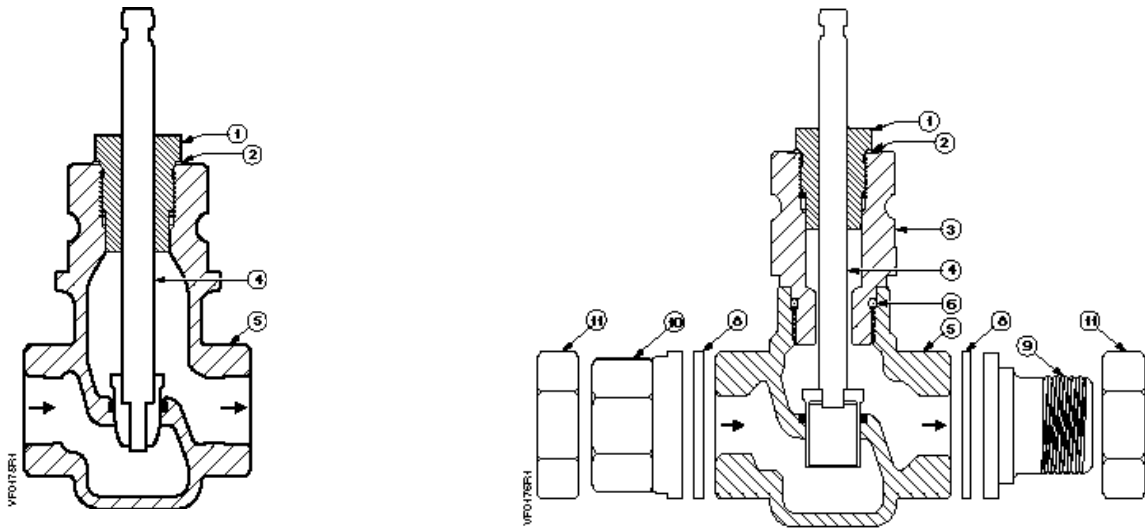

**1/2-inch (15 mm) Line Size Valve**

**3/4-inch to 2-inch (20 to 50 mm) Line Size Valve**

**Figure 8. Normally Open.**

**Parts List**

**Table 13. Parts List for 2-Way Bronze Valves. See Figures 7 and 8.**

Item	Part Name	Part Number	Quantity				Material
			FxF	FxUF	FxUM	UFxUF	
1	Packing Cartridge Assembly	—	1	1	1	1	—
2	Gasket	—	1	1		1	Copper
3	Normally Open 3/4-inch to 2-inch Bonnet	—	1	1	1	1	Brass
4	Stem and Plug Assembly	—	1	1	1	1	Bronze or Stainless Steel
5	Valve Body	—	1	1	1	1	Bronze
6	O-ring		1	1	1	1	EPDM
7	Normally closed Cap	—	1	1	1	1	Brass
8	Gasket	—	—	1	1	2	Fiber
9	NPT Male union tail piece	—	—	—	1	—	Brass
10	Female tail piece	—	—	1	—	2	Brass
11	Union Nut	—	—	1	1	2	Brass
—	Packing Kit Normal Duty Service Steam Service	599-03390 599-03391	—	—	—	—	Items 1 and 2
—	Rebuild/Repack Kit Normally Closed	See Table 14	—	—	—	—	Items 1, 2, 4, and 6
—	Rebuild/Repack Kit Normally Open	See Table 14	—	—	—	—	Items 1, 2, 4, and 6

**Valve Assembly  
 Weight**

**Table 14. Weight in Pounds (Kilograms).**

Line Size	Normally Closed				Normally Open			
	FxF	FxUF	FxUM	UFxUF	FxF	FxUF	FxUM	UFxUF
.50 (15)	3 (1.4)	4 (1.8)	4 (1.8)	— —	3 (1.4)	3 (1.4)	3 (1.4)	— —
.75 (20)	4 (1.8)	4 (1.8)	5 (2.3)	— —	4 (1.8)	4 (1.8)	5 (2.3)	— —
1.0 (25)	5 (2.3)	5 (2.3)	5 (2.3)	— —	5 (2.3)	6 (2.7)	6 (2.7)	— —
1.25 (32)	7 (3.2)	— —	— —	9 (4.1)	7 (3.2)	— —	8 (3.6)	9 (4.1)
1.50 (40)	8 (3.6)	— —	— —	11 (5)	9 (4.1)	— —	— —	11 (5)
2.0 (50)	16 (7.3)	— —	— —	16 (7.3)	13 (5.9)	— —	— —	16 (7.3)



**Service Kit NOTE:** To select the service kit, know your valve body assembly number, model number and the type of connection. Read down the *Connection* column until you find the valve body assembly number and then read to the far right to identify the correct kit. The valve body assembly number and model number are stamped on the tag on the valve body.

**Table 15. Rebuild/Repack Service Kits Part Numbers. See Table 12 for Items in Kit.**

Connection				Valve Description	Model 1 Kit No.	Model 2 Kit No.
FxF	FxUF	UFxUF	FxUM			
599-03000	599-03009	—	599-03216	NO 1/2" Linear SS 1.0 Cv O-ring	599-03300	—
599-03001	599-03010	—	599-03217	NO 1/2" Linear SS 1.6 Cv O-ring	599-03301	—
599-03002	599-03011	—	599-03218	NO 1/2" Linear SS 2.5 Cv O-ring	599-03302	—
599-03003	599-03012	—	599-03219	NO 1/2" Linear SS 4.0 Cv O-ring	599-03303	—
599-03004	599-03013	—	599-03220	NO 3/4" Linear SS O-ring	599-03304	—
599-03005	599-03014	—	599-03221	NO 1" Linear SS O-ring	599-03305	—
599-03006	—	599-03015	—	NO 1-1/4" Linear SS O-ring	599-03306	599-09201
599-03007	—	599-03016	—	NO1-1/2" Linear SS O-ring	599-03307	599-09202
599-03008	—	599-03017	—	NO 2" Linear SS O-ring	599-03308	599-09203
599-03018	599-03027	—	599-03225	NC 1/2" Linear SS 1.0 Cv O-ring	599-03309	—
599-03019	599-03028	—	599-03226	NC 1/2" Linear SS 1.6 Cv O-ring	599-03310	—
599-03020	599-03029	—	599-03227	NC 1/2" Linear SS 2.5 Cv O-ring	599-03311	—
599-03021	599-03030	—	599-03228	NC 1/2" Linear SS 4.0 Cv O-ring	599-03312	—
599-03022	599-03031	—	599-03229	NC 3/4" Linear SS O-ring	599-03313	—
599-03023	599-03032	—	599-03230	NC 1" Linear SS O-ring	599-03314	—
599-03024	—	599-03033	—	NC 1-1/4" Linear SS O-ring	599-03315	599-09213
599-03025	—	599-03034	—	NC 1-1/2" Linear SS O-ring	599-03316	599-09214
599-03026	—	599-03035	—	NC 2" Linear SS O-ring	599-03317	599-09215
599-03054	599-03063	—	599-03234	NO 1/2" Linear SS 1.0 Cv Steam	599-03318	—
599-03055	599-03064	—	599-03235	NO 1/2" Linear SS 1.6 Cv Steam	599-03319	—
599-03056	599-03065	—	599-03236	NO 1/2" Linear SS 2.5 Cv Steam	599-03320	—
599-03057	599-03066	—	599-03237	NO 1/2" Linear SS 4.0 Cv Steam	599-03321	—
599-03058	599-03067	—	599-03238	NO 3/4" Linear SS Steam	599-03322	—
599-03059	599-03068	—	599-03239	NO 1" Linear SS Steam	599-03323	—
599-03060	—	599-03069	—	NO 1-1/4" Linear SS Steam	599-03324	599-09204
599-03061	—	599-03070	—	NO 1-1/2" Linear SS Steam	599-03325	599-09205
599-03062	—	599-03071	—	NO 2" Linear SS Steam	599-03326	599-09206
599-03072	599-03081	—	599-03243	NC 1/2" Linear SS 1.0 Cv Steam	599-03327	—
599-03073	599-03082	—	599-03244	NC 1/2" Linear SS 1.6 Cv Steam	599-03328	—
599-03074	599-03083	—	599-03245	NC 1/2" Linear SS 2.5 Cv Steam	599-03329	—
599-03075	599-03084	—	599-03246	NC 1/2" Linear SS 4.0 Cv Steam	599-03330	—
599-03076	599-03085	—	599-03247	NC 3/4" Linear SS Steam	599-03331	—
599-03077	599-03086	—	599-03248	NC 1" Linear SS Steam	599-03332	—
599-03078	—	599-03087	—	NC 1-1/4" Linear SS Steam	599-03333	599-09216
599-03079	—	599-03088	—	NC 1-1/2" Linear SS Steam	599-03334	599-09217
599-03080	—	599-03089	—	NC 2" Linear SS Steam	599-03335	599-09218

## Service Kits, Continued

**Table 16. Rebuild/Repack Service Kits Part Numbers Continued. See Table 13 for Items in Kit.**

Connection				Valve Description	Model 1 Kit No.	Model 2 Kit No.
FxF	FxUF	UFxUF	FxUM			
599-03108	599-03117	—	599-03252	NO 1/2" =% SS 1.0 Cv O-ring	599-03336	—
599-03109	599-03118	—	599-03253	NO 1/2" =% SS 1.6 Cv O-ring	599-03337	—
599-03110	599-03119	—	599-03254	NO 1/2" =% SS 2.5 Cv O-ring	599-03338	—
599-03111	599-03120	—	599-03255	NO 1/2" =% SS 4.0 Cv O-ring	599-03339	—
599-03112	599-03121	—	599-03256	NO 3/4" =% SS O-ring	599-03340	—
599-03113	599-03122	—	599-03257	NO 1" =% SS O-ring	599-03341	—
599-03114	—	599-03123	—	NO 1-1/4" =% SS O-ring	599-03342	599-09207
599-03115	—	599-03124	—	NO 1-1/2" =% SS O-ring	599-03343	599-09208
599-03116	—	599-03125	—	NO 2" =% SS O-ring	599-03344	599-09209
599-03126	599-03135	—	599-03261	NC 1/2" =% SS 1.0 Cv O-ring	599-03345	—
599-03127	599-03136	—	599-03262	NC 1/2" =% SS 1.6 Cv O-ring	599-03346	—
599-03128	599-03137	—	599-03263	NC 1/2" =% SS 2.5 Cv O-ring	599-03347	—
599-03129	599-03138	—	599-03264	NC 1/2" =% SS 4.0 Cv O-ring	599-03348	—
599-03130	599-03139	—	599-03265	NC 3/4" =% SS O-ring	599-03349	—
599-03131	599-03140	—	599-03266	NC 1" =% SS O-ring	599-03350	—
599-03132	—	599-03141	—	NC 1-1/4" =% SS O-ring	599-03351	599-09219
599-03133	—	599-03142	—	NC 1-1/2" =% SS O-ring	599-03352	599-09220
599-03134	—	599-03143	—	NC 2" =% SS O-ring	599-03353	599-09221
599-03162	599-03171	—	599-03270	NO 1/2" =% BZ 1.0 Cv O-ring	599-03354	—
599-03163	599-03172	—	599-03271	NO 1/2" =% BZ 1.6 Cv O-ring	599-03355	—
599-03164	599-03173	—	599-03272	NO 1/2" =% BZ 2.5 Cv O-ring	599-03356	—
599-03165	599-03174	—	599-03273	NO 1/2" =% BZ 4.0 Cv O-ring	599-03357	—
599-03166	599-03175	—	599-03274	NO 3/4" =% BZ O-ring	599-03358	—
599-03167	599-03176	—	599-03275	NO 1" =% BZ O-ring	599-03359	—
599-03168	—	599-03177	599-03276	NO 1-1/4" =% BZ O-ring	599-03360	599-09210
599-03169	—	599-03178	—	NO 1-1/2" =% BZ O-ring	599-03361	599-09211
599-03170	—	599-03179	—	NO 2" =% BZ O-ring	599-03362	599-09212
599-03180	599-03189	—	599-03279	NC 1/2" =% BZ 1.0 Cv O-ring	599-03363	—
599-03181	599-03190	—	599-03280	NC 1/2" =% BZ 1.6 Cv O-ring	599-03364	—
599-03182	599-03191	—	599-03281	NC 1/2" =% BZ 2.5 Cv O-ring	599-03365	—
599-03183	599-03192	—	599-03282	NC 1/2" =% BZ 4.0 Cv O-ring	599-03366	—
599-03184	599-03193	—	599-03283	NC 3/4" =% BZ O-ring	599-03367	—
599-03185	599-03194	—	599-03284	NC 1" =% BZ O-ring	599-03368	—
599-03186	—	599-03195	—	NC 1-1/4" =% BZ O-ring	599-03369	599-09222
599-03187	—	599-03196	—	NC 1-1/2" =% BZ O-ring	599-03370	599-09223
599-03188	—	599-03197	—	NC 2" =% BZ O-ring	599-03371	599-09224

Information in this publication is based on current specifications. The company reserves the right to make changes in specifications and models as design improvements are introduced. Flowrite is a registered trademark of Siemens Building Technologies, Inc. Product or company names mentioned herein may be the trademarks of their respective owners. © 2008 Siemens Building Technologies, Inc.